

Powder dosing machines - customized solutions



PFW 15 with bucket conveyor in double line

The above shown customized dosing machine for powder PFW 15 has in total 15 dosing stations, thereof

- 5 for Big-Bag-charging,
- 8 for paper sack charging and
- 2 for hand dosing

The weighing process is integrated in the bucket conveyor with 2 buckets. The bucket conveyor is construed for ascending slope.

The use of this special bucket conveyor allows a lower installation height.

Solutions with double line available

Subject to change without prior notice.

Powder dosing machines - customized solutions



PFW 10 with 2 bucket conveyors for the discharge onto 7 down pipes for delivery onto 7 skip hoists (down pipes swing able and additional storage possibility)

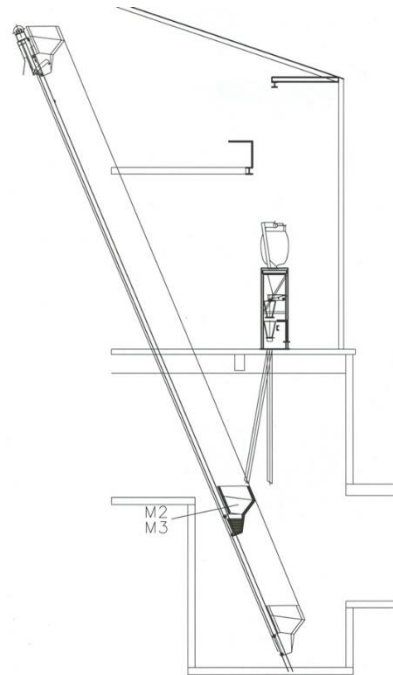

Side view PFW 10 with bucket conveyor and down pipes with discharge into the skip hoists

How may we customize your machine?



PF 6 and PF 4 S for paper sack charging with bucket conveyor for the discharge onto the moving bucket scale for aggregates

PRODUCT INFORMATION

Subject to change without prior notice.