

# Fibre dosing machine FS 1700/400 for the dosing of short-cut fibres



Mobile solution: FS 1700/400 with catwalk and control system DS 4

Suitable for the dosing of

- Synthetic fibres
- Glass fibres
- Natural fibres

applicable for

- Fibre length 6-30 mm  
 (we would be pleased to test other fibres and lengths on our machine for you)

- Basic unit with retractable catwalk
- with forklift shoes for forklift handling
- with below mounted collating and weighing conveyor
- with built-on power cabinet
- electronic control system DS 4 touch fibre (optional)

We offer solutions for stationary and mobile application



Optional: control system DS 4 touch fibre available integrated in table housing or power cabinet



FS 1700/400 during charging view discharging collating and weighing conveyor



FS 1700/400 ready for transport

PRODUCT INFORMATION

Subject to change without prior notice.

# Fibre dosing machine FS 1700/400 for the dosing of short-cut fibres

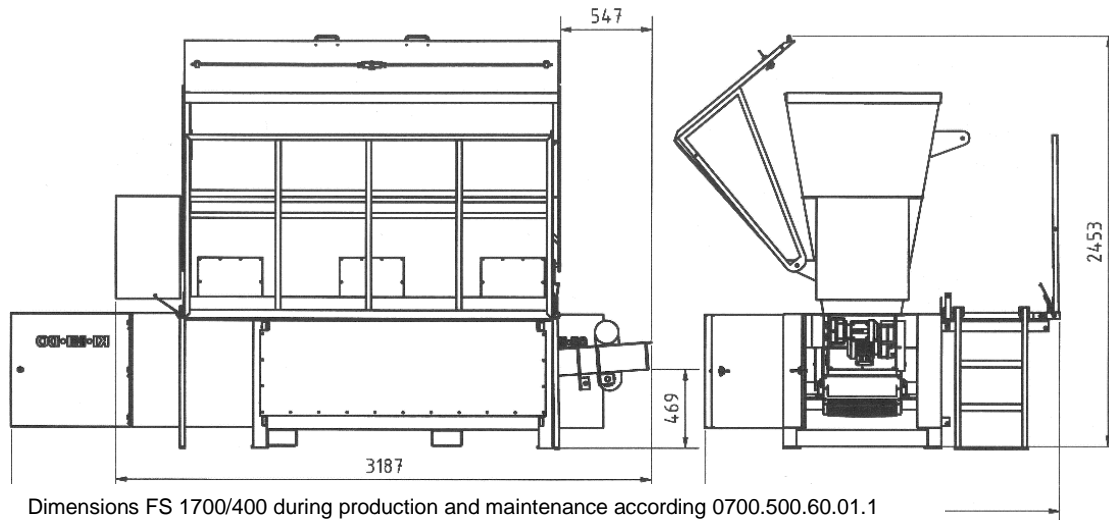

Dimensions FS 1700/400 during production and maintenance according 0700.500.60.01.1

Dimensions are approx. and in millimetres (mm)!

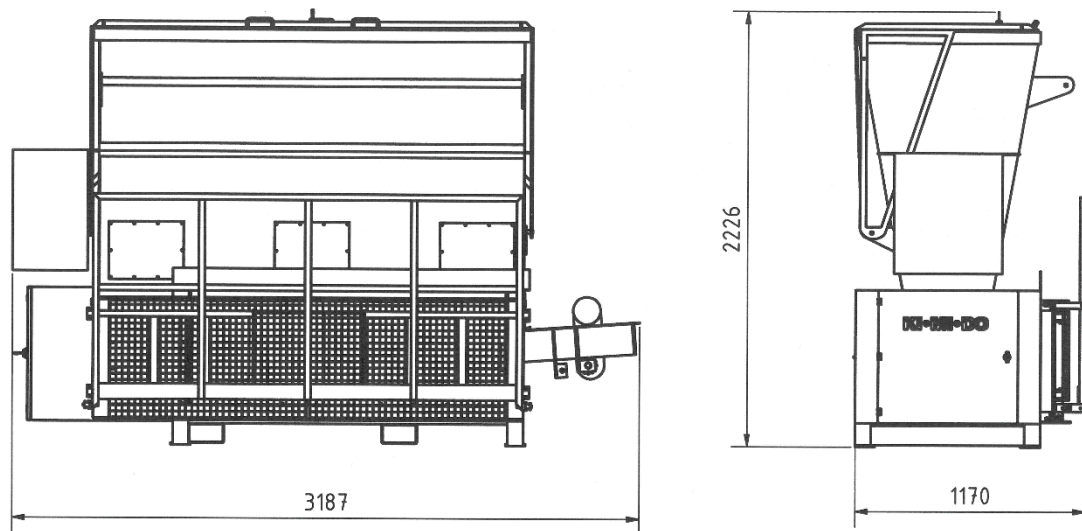

Dimensions FS 1700/400 during transport according 0700.500.60.01.2

Dimensions are approx. and in millimetres (mm)!

## Fibre dosing machine FS 1700/400

### Technical data:

Volume of storage bin	approx. 1700 l
Discharge performance	10-60 l/min
Operating voltage	230/400 V, 50 Hz

### Collating and weighing conveyor

Belt width	400 mm
Belt velocity	1,18 m/Sec.
Weighing range	0,1-20 kg
Load cell division/ weighing accuracy	20 g / ± 20 g

### Optional available:

#### Electronic control system DS 4 touch fibre

Microprocessor controlled dosing system, LC-Display 10.4", with integrated keypad, optional extension for connection of PC and log printer.

PRODUCT INFORMATION

Subject to change without prior notice.

# Fibre dosing machine FS 1700/400 for the dosing of short-cut fibres

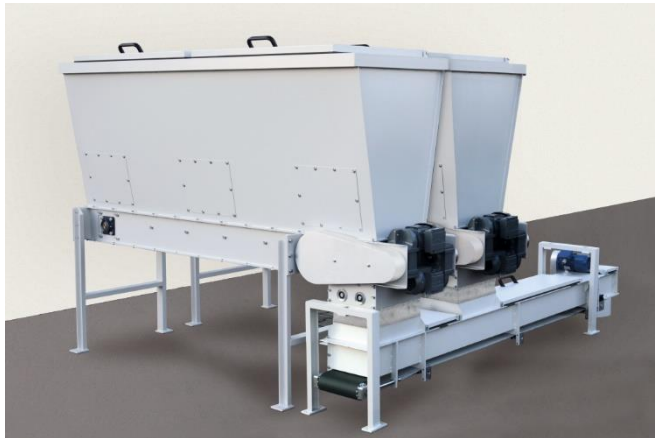

**Stationary solution:**  
 Customized design

2 Fibre dosing machines FS 1000/400  
 with storage bin V=1000 l each  
 with crosswise mounted collating and weighing  
 conveyor

**Examples for fibre dosing machines in use**

**Mobile solution:**  
 Fibre dosing machine FS 1700/400  
 with 2 hinged covers on the storage bin  
 with retractable catwalk  
 and mounted belt conveyor for  
 discharging into the mixer



**Stationary solution:**  
 Customized design

Fibre dosing machine FS 1700/400  
 with storage bin volume V=1700l  
 with stationary catwalk  
 with collating and weighing conveying in customized length  
 and mounted belt conveyor for discharging into the mixer

PRODUCT INFORMATION

Subject to change without prior notice.