

Dosing machine for granulates

Type FD . G/MB . G - Pneumatic conveying



Fig.: FD 4 G

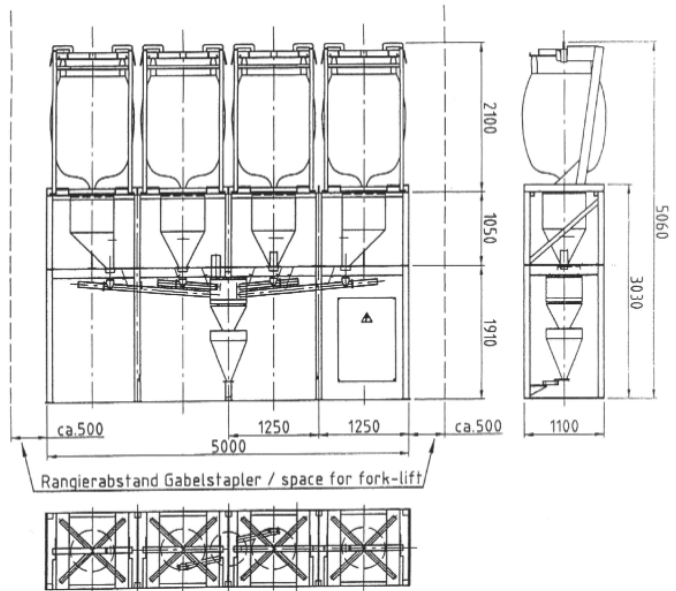

Fig. Dimensions FD 4 G

Dimensions and sizes are approx. and in Millimetres (mm)!

Available as

- Pigment dosing machine type FD . G (in-line design)
- Compact pigment dosing machine type MB . G



Subject to change without prior notice!

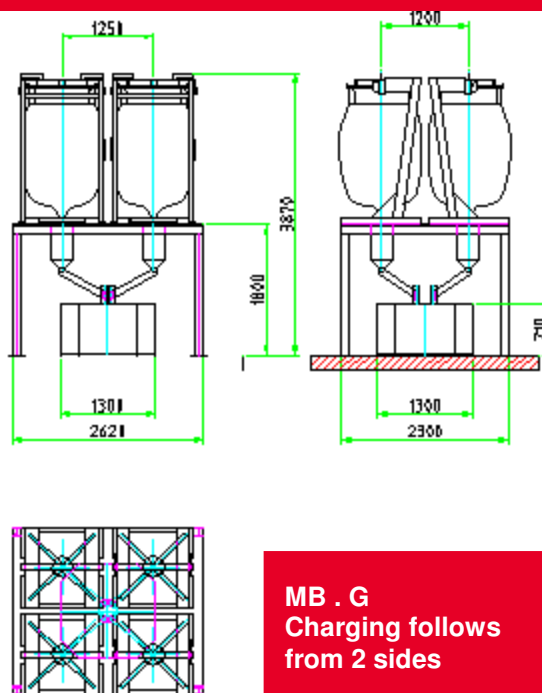

MB . G
Charging follows
from 2 sides

Dimensions and sizes are approx and in Millimetres (mm)!

KI MI DO
KINDLER GMBH
Misch- und Dosiertechnik

Siemensstraße 11
D-72160 Horb a.N.

Fon +49 (0) 74 51 10 22
Fax +49 (0) 74 51 66 22

info@kimido.com
www.kimido.com

Dosing machine for granulates

Type FD . G/MB . G - Pneumatic conveying

The pigment dosing machine type FD . G (in-line design) is available with following numbers of components:

FD 2 G	Basic unit, 2 Big-Bag-steel racks and lifting hooks
FD 3 G	Basic unit, 3 Big-Bag-steel racks and lifting hooks
FD 4 G	Basic unit, 4 Big-Bag-steel racks and lifting hooks
FD 5 G	Basic unit, 5 Big-Bag-steel racks and lifting hooks
FD 6 G	Basic unit, 6 Big-Bag-steel racks and lifting hooks

Other designs on inquiry.

The compact dosing machine type MB . G is available with following numbers of components:

MB 2 G	Basic unit, 2 Big-Bag-steel racks and lifting hooks
MB 3 G	Basic unit, 3 Big-Bag-steel racks and lifting hooks
MB 4 G	Basic unit, 4 Big-Bag-steel racks and lifting hooks
MB 5 G	Basic unit, 5 Big-Bag-steel racks and lifting hooks
MB 6 G	Basic unit, 6 Big-Bag-steel racks and lifting hooks

Other designs on inquiry.

Charging possibilities:

- Big-Bag-steel rack with lifting hook (included in standard scope of supply)
- Changeable PVC-silo 1,2 m³ (additional price)



Big-Bag-steel rack with lifting hook



Changeable PVC-silo 1,2 m³

Overview accessory parts:

- Pneumatic conveying hose NW 50
- Clamps for pneumatic conveying hose
- Two-way distributor for pigment distribution onto 2 mixers (only in connection with control system DS 5)
- Three-way distributor for pigment distribution onto 3 mixers (only in connection with control system DS 5)
- Control system DS 4 (control of max. 1 mixer)
Control system DS 5
- Mixer mounted dust collector size VII 7,5 m²
- Pigment storage pod size 7,5 m² V= 60 l

KI MI DO
KINDLER GMBH

Misch- und Dosiertechnik

Siemensstraße 11
D-72160 Horb a.N.

Fon +49 (0) 74 51 10 22
Fax +49 (0) 74 51 66 22

info@kimido.com
www.kimido.com

Subject to change without prior notice!